

# HYDRAULIC FLOOR CRANE U-TYPE

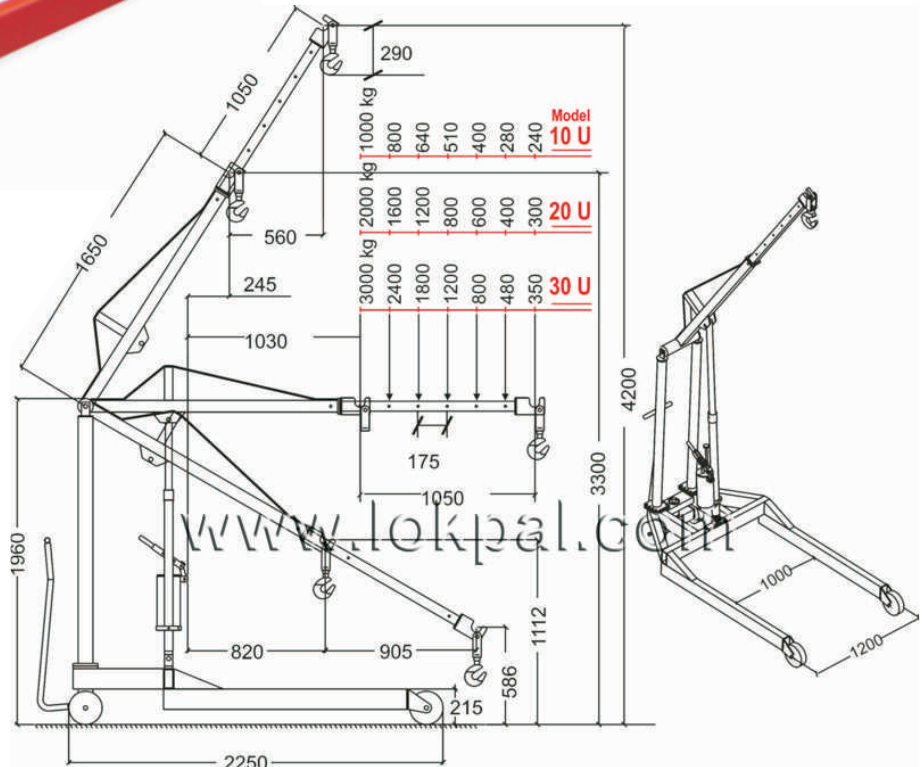

Model 10 U  
Model 20 U  
Model 30 U

U-type for loads kept between legs



## Features

The chassis is (U) shaped and the job to be lifted is accommodated within the frame itself. The equipment is use full for loading and unloading jobs into trucks & other areas, where the legs can be easily moved. Slide under obstructions. The advantage of this equipment is that being shorter in length it has a small turning radius and no counter weights are required for loading moment.

## LOKPAL INDUSTRIES

A-6, Sector-3, Noida-201301, U.P., India | Tel.: +91-120-3065372 / 75

Website: [www.lokpal.com](http://www.lokpal.com) | E-mail: [info@lokpal.com](mailto:info@lokpal.com)