

HIGH LIFT PALLET TRUCK

**Telescopic
Cylinder
Design**

HL-680M



HLPT-10-540
HLPT-10-680
HLPT-15-540
HLPT-15-680

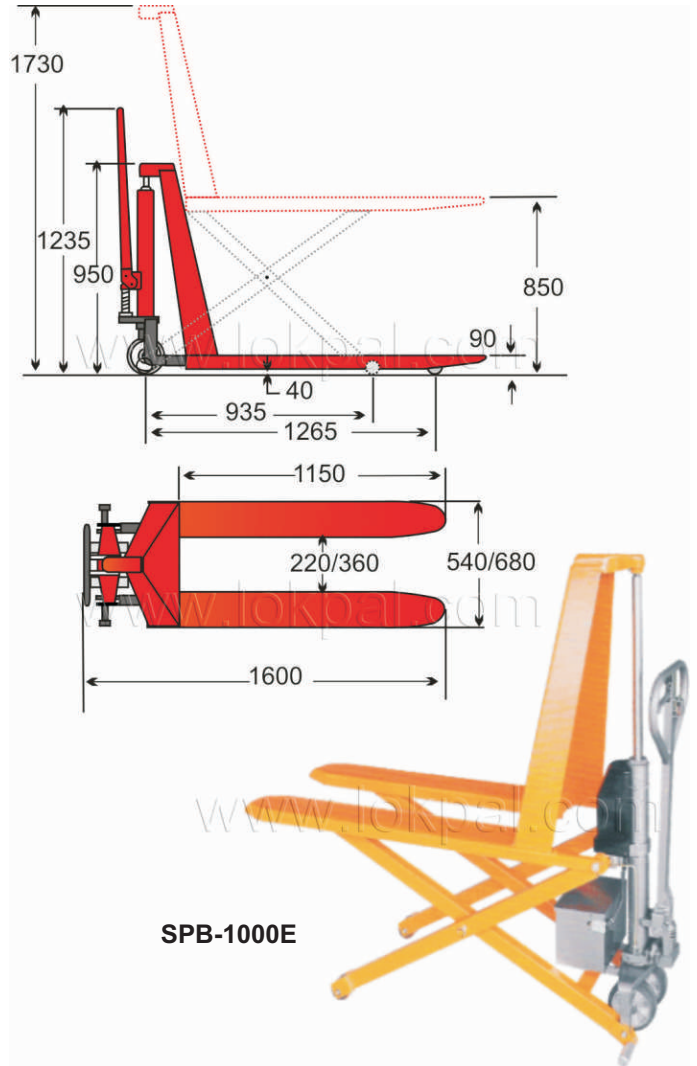

Specifications:

		Fork	Fork	Min.	Max.
Model	Capacity	Span	Length	Fork	Fork
				Height	Height
	Kg	mm	mm	mm	mm
High Lift Pallet Truck					
HLPT-10-540	1000	540	1150	90	850
HLPT-10-680	1000	680	1150	90	850
HLPT-15-540	1500	540	1150	90	850
HLPT-15-680	1500	680	1150	90	850
High Lift Pallet Truck (Telescopic Cylinder)					
HL-680M	1000	680	1165	85	800
Electric High Lift Pallet Truck					
SPB -1000E	1000	540	1150	85	800

Two robust size stabilizers automatically come in contact with the ground when the forks reach a height of 240mm.

After this the steering wheels are raised off the ground and the truck is then immobile, giving good stability. The truck can only be moved at lift heights below 240mm

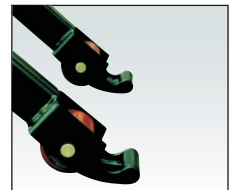

Front support legs

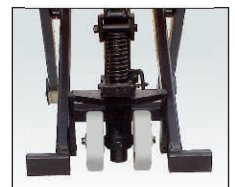

Side stabilizers

LOKPAL INDUSTRIES

A-6, Sector-3, Noida-201301, U.P., India | Tel.: +91-120-3065372 / 75

Website: www.lokpal.com | E-mail: info@lokpal.com