

# FOUR POST PARKING LIFT DFP608

## DFP608E, DFP608NE, DFP608FE

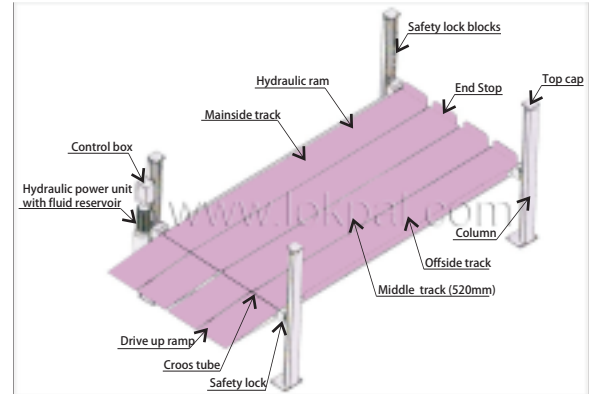

DFP-608FE\* (4 Pieces platforms)

### Specifications :

| DFP608NE              |          | DFP608** / 608E / 608FE |          | Features |
|-----------------------|----------|-------------------------|----------|----------|
| Lifting capacity      | 3700kgs  | Lifting capacity        | 3700kgs  |          |
| Lifting height        | 1900mm   | Lifting height          | 1800mm   |          |
| Overall height        | 2138mm   | Overall height          | 2086mm   |          |
| Width between posts   | 2353mm   | Width between posts     | 2353mm   |          |
| Width between runways | 949.5mm  | Width between runways   | 949.5mm  |          |
| Up/Down time          | 60/90Sec | Up/Down time            | 60/90Sec |          |
| Power                 | 2.20v    | Power                   | 2.20v    |          |

## LOKPAL INDUSTRIES

A-6, Sector-3, Noida-201301, U.P., India | Tel.: +91-120-3065372 / 75

Website: [www.lokpal.com](http://www.lokpal.com) | E-mail: [info@lokpal.com](mailto:info@lokpal.com)

# TWO POST PARKING LIFT DTPP607N

Low Cost

Light duty parking

lift for small car

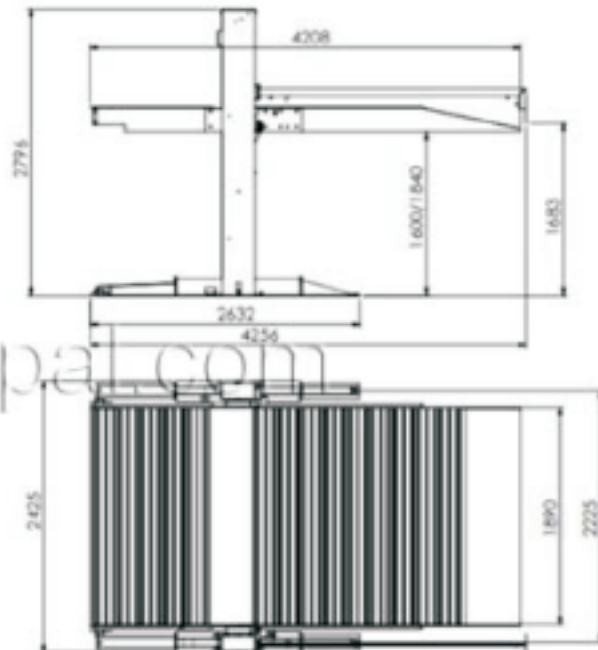

## Specifications :

|                  | DTPP607 | DTPP607N      |
|------------------|---------|---------------|
| Lifting capacity | 3200kgs | 2200kgs       |
| Lifting height   | 1800mm  | 1600mm/1800mm |
| Platform width   | 2120mm  | 1890mm        |
| Overall width    | 2646mm  | 2424mm        |
| Overall length   | 4303mm  | 4256mm        |
| Power            | 2.20v   | 2.20v         |

## Features

- Instantly double your parking space
- Ideal for Indian conditions.
- Electric lock release.
- Simple installation.
- Diamond plate runway and ramps for easy to use.
- Complete cover under runways to protect your vehicle.

## LOKPAL INDUSTRIES

A-6, Sector-3, Noida-201301, U.P., India | Tel.: +91-120-3065372 / 75

Website: [www.lokpal.com](http://www.lokpal.com) | E-mail: [info@lokpal.com](mailto:info@lokpal.com)

# TWO POST PARKING LIFT DEP606

**Tilting Deck ensures low car height for use in low head room areas**



**DEP606 (Tilted Deck)**

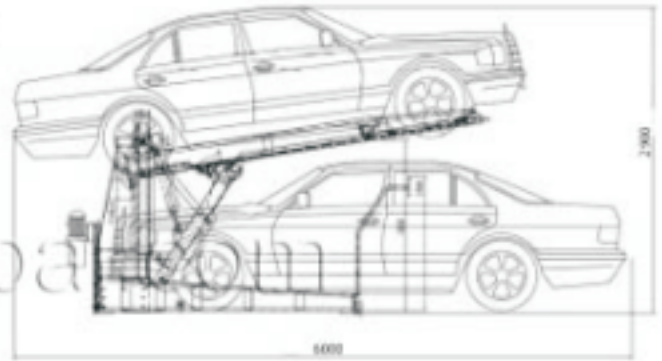

## Features

- Easy operation
- Safe performance
- Convenient parking
- Easy and quick installation
- Used for residential and office buildings

## Specifications :

| DEP606           |         |
|------------------|---------|
| Lifting capacity | 2700kgs |
| Lifting height   | 1900mm  |
| Max width        | 2500mm  |
| Overall height   | 1955mm  |
| Power            | 2.20v   |

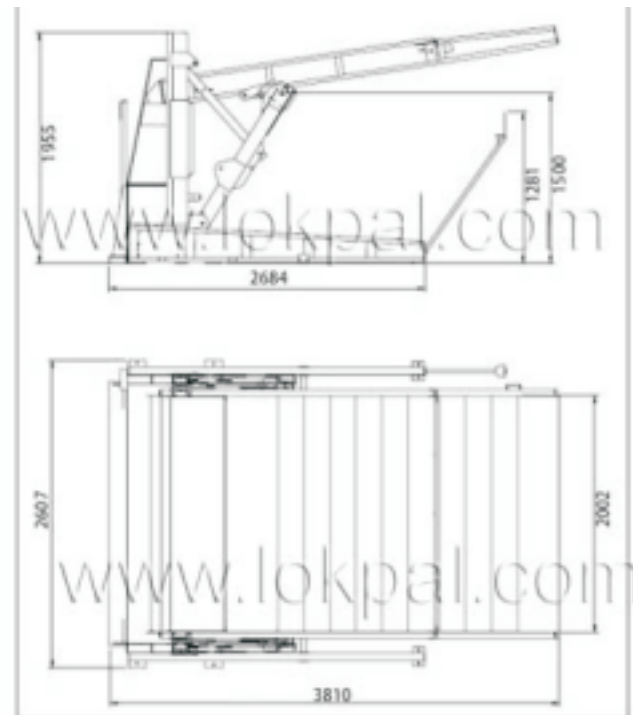

## LOKPAL INDUSTRIES

A-6, Sector-3, Noida-201301, U.P., India | Tel.: +91-120-3065372 / 75

Website: [www.lokpal.com](http://www.lokpal.com) | E-mail: [info@lokpal.com](mailto:info@lokpal.com)



# TWO POST PARKING SYSTEM DTPP606



Save space  
with shared columns  
for  
multiple units parking



## Features

They are engineered to lift motor vehicles for parking purposes

but also suitable for car dealers to use as a showcase.

Multi-channel safety protection.

Multiple units can be linked via sharing the common column.

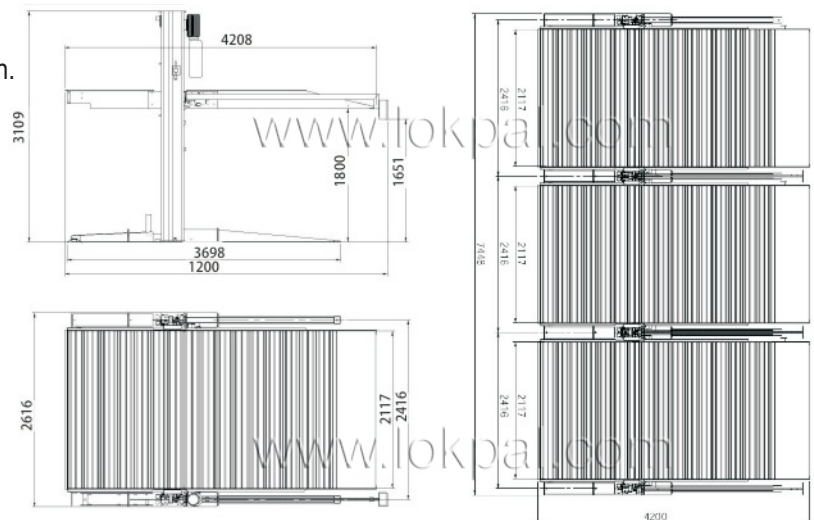

## Specifications :

### DTPP606

|                   |               |
|-------------------|---------------|
| Lifting capacity  | 2700kgs       |
| Lifting height    | 1600mm/1800mm |
| Overall height    | 3109mm        |
| Platform width    | 2117mm        |
| Per unit: parking | 2 cars        |

## LOKPAL INDUSTRIES

A-6, Sector-3, Noida-201301, U.P., India | Tel.: +91-120-3065372 / 75

Website: [www.lokpal.com](http://www.lokpal.com) | E-mail: [info@lokpal.com](mailto:info@lokpal.com)



# SCISSOR PARKING LIFT DSPL606

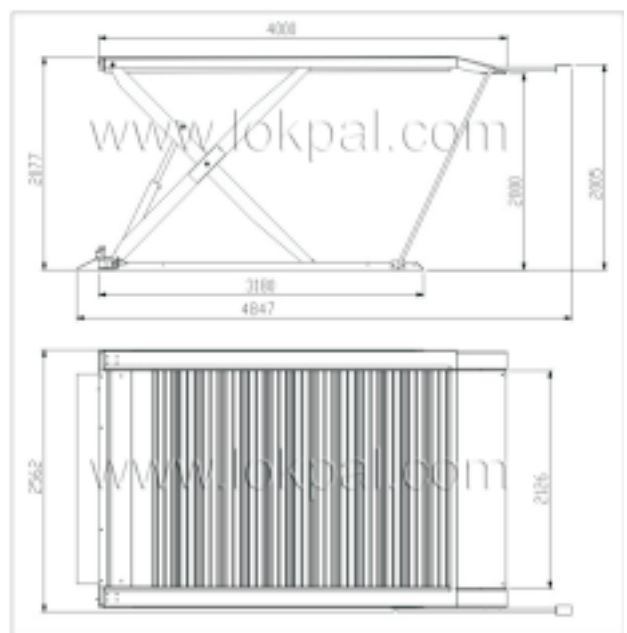

## Specifications :

| DSPL606          |          | Features  |
|------------------|----------|---|
| Lifting capacity | 2200kgs  | Light weight, easy to move,<br>No obstructions of columns |
| Lifting height   | 1950mm   |   |
| Lifting Speed    | 3.5m/min |   |

## LOKPAL INDUSTRIES

A-6, Sector-3, Noida-201301, U.P., India | Tel.: +91-120-3065372 / 75

Website: [www.lokpal.com](http://www.lokpal.com) | E-mail: [info@lokpal.com](mailto:info@lokpal.com)

# GARAGE EQUIPMENTS



**Model No. - SP-15101**  
Description - Engine Support  
Capacity - 300Kg



**Model No. - SP-08102**  
Description - Transmission Adaptor  
Capacity - 1000lbs

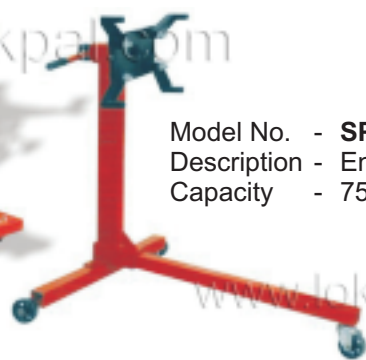

**Model No. - SP-04101**  
Description - Engine Stand  
Capacity - 750lbs



**Model No. - SP-14101**  
Description - Cross Beam Adaptor  
Capacity - 2Ton



**Model No. - SPO-081011**  
Description - Tall Transmission Jack  
Capacity - 1000lbs



**Model No. - SP-21201**  
Description - Work Table Cart  
Capacity - 200lbs



**TR-4001-20**  
Parts Washer



**Model No. - SP-05201**  
Description - Hydraulic Shop Press  
Capacity - 12Ton



**Model No. - SP-08301**  
Description - Transmission Adaptor  
Capacity - 0.5Ton



Stool  
TR-6185-1

**Model No. - SP-05401**  
Description - Hydraulic Shop Press  
Capacity - 30Ton



**Model No. - TRM-03003-4**  
Description - Horizontal Pipe Bending Machine  
Capacity - 2/3/6Ton

## LOKPAL INDUSTRIES

A-6, Sector-3, Noida-201301, U.P., India | Tel.: +91-120-3065372 / 75

Website: [www.lokpal.com](http://www.lokpal.com) | E-mail: [info@lokpal.com](mailto:info@lokpal.com)

# FOUR POST CAR LIFT



## 4QJY4.0-B

### Specifications : (Four Post Lift):

|                            |     |                |
|----------------------------|-----|----------------|
| Model                      |     | 4QJY 4.0-B     |
| Rated Elevating Weight     | Ton | 4.0            |
| Min. Ground Clearance      | mm  | 150            |
| Max. Ground Clearance      | mm  | 1750           |
| Secondary Elevating Height | mm  | 200            |
| Power of Motor             | Kw  | 2.2            |
| Power Supply               | V   | 440            |
| Hydraulic Oil              | mm  | 46             |
| Dimensions                 | mm  | 4610x3070x2118 |

## LOKPAL INDUSTRIES

A-6, Sector-3, Noida-201301, U.P., India | Tel.: +91-120-3065372 / 75

Website: [www.lokpal.com](http://www.lokpal.com) | E-mail: [info@lokpal.com](mailto:info@lokpal.com)



# TWO POST CAR LIFT



QJY-3000A

**Automotive Lift Duplex Cylinder  
QJY3.0-D**

**Automotive Lift Duplex Gantry  
QJY3.0-B**



**Specifications :** (Two Post Lift):

| Model                 |     | QJY 3000 A | QJY3.0-D | QJY 3.0-B |
|-----------------------|-----|------------|----------|-----------|
| Capacity              | Ton | 3.0        | 3.0      | 3.0       |
| Lift Height           | mm  | >1700      | >1700    | >1700     |
| Rise Time             | S   | <50        | <50      | <50       |
| Drop Time             | S   | >20        | >20      | >20       |
| Power of Motor        | Kw  | 2.2        | 2.2      | 2.2       |
| Power Supply          | V   | 440        | 440      | 440       |
| Height of Rack        | mm  | 2850       | 2830     | 3490      |
| Width Between Pillars | mm  | 2460       | 2690     | 2900      |

## LOKPAL INDUSTRIES

A-6, Sector-3, Noida-201301, U.P., India | Tel.: +91-120-3065372 / 75

Website: [www.lokpal.com](http://www.lokpal.com) | E-mail: [info@lokpal.com](mailto:info@lokpal.com)

# MOTOR CYCLE LIFTABLE



**TRE 64007 G**

**The Machine is fitted with both pneumatic (air hydraulic) and foot pump. Either pump can be selected for lifting.**



#### Specifications:

|               |    |             |
|---------------|----|-------------|
| Model         |    | TRE 64007 G |
| Capacity      | Kg | 450         |
| Min. Height   | mm | 175         |
| Max. Height   | mm | 750         |
| Platform Size | mm | 2200 x 680  |
| Leading Plate | mm | 650 x 680   |

## LOKPAL INDUSTRIES

A-6, Sector-3, Noida-201301, U.P., India | Tel.: +91-120-3065372 / 75

Website: [www.lokpal.com](http://www.lokpal.com) | E-mail: [info@lokpal.com](mailto:info@lokpal.com)



**SC 1350**



**Specifications :** (Tool Cart):

| Model   | Capacity<br>(Kg) | Height    | Width     | Length    |
|---------|------------------|-----------|-----------|-----------|
|         |                  | (H)<br>mm | (W)<br>mm | (L)<br>mm |
| SC 1350 | 70               | 825       | 410       | 838       |

## LOKPAL INDUSTRIES

A-6, Sector-3, Noida-201301, U.P., India | Tel.: +91-120-3065372 / 75

Website: [www.lokpal.com](http://www.lokpal.com) | E-mail: [info@lokpal.com](mailto:info@lokpal.com)





**TBD-134 G**



**TBC-128**



**TBD-134**



**Stainless Steel  
Tool Box**

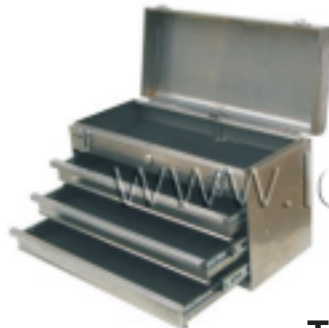

**TBD-133A-S**



**Specifications :**

| Model  |    | TBD<br>134 | TBD<br>134G | TBC<br>128 | TBD<br>133A-S |
|--------|----|------------|-------------|------------|---------------|
| Length | mm | 435        | 520         | 500        | 497           |
| Width  | mm | 250        | 220         | 210        | 217           |
| Height | mm | 300        | 375         | 175        | 298           |



### Combination Kit

**Specifications:**

| Model  | Cap. | Min. Ht. | Max. Ht. |
|--------|------|----------|----------|
|        | Ton  | mm       | mm       |
| HJS 20 | 2    | 278      | 425      |
| HJS 30 | 3    | 386      | 425      |
| HJS 40 | 4    | 330      | 505      |
| HJS 60 | 6    | 388      | 610      |

### Bottle Jack

T-91203  
12Ton

**Specifications:**

| Model   | Cap. | Min. Height | Lifting Height | Adjustable Height |
|---------|------|-------------|----------------|-------------------|
| T-91203 | Ton  | mm          | mm             | mm                |
|         | 12   | 181         | 116            | 48                |



### Portable Sandblaster

TR 4012

**Specifications:**

(Portable Sandblaster):

| Model   | Tank Size mm | Overall Size mm | Hose Lg m | Pressure psi |
|---------|--------------|-----------------|-----------|--------------|
| TR 4012 | ø304, 609    | 830x480x330     | 2.5       | 60~125       |



# TOE JACK



## Specification:

| Model | Cap. | Lifting of foot | Lifting of head | Lowest of foot/head |
|-------|------|-----------------|-----------------|---------------------|
| HJ-10 | Ton  | mm              | mm              | mm                  |
|       | 10   | 265             | 660             | 30/425              |

## LOKPAL INDUSTRIES

A-6, Sector-3, Noida-201301, U.P., India | Tel.: +91-120-3065372 / 75

Website: [www.lokpal.com](http://www.lokpal.com) | E-mail: [info@lokpal.com](mailto:info@lokpal.com)



# ELECTRIC WINCH

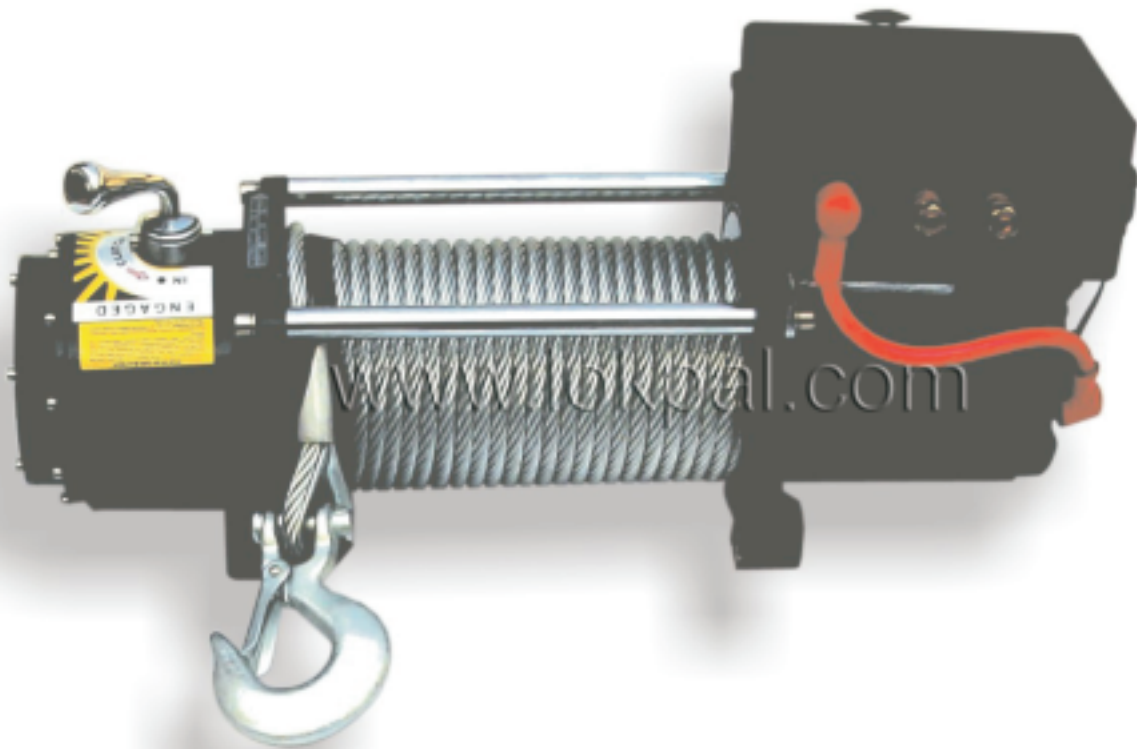

TRH 98000



## Specifications :

### (Electric Winch):

|               |                       |
|---------------|-----------------------|
| Capacity      | 3500Kg                |
| Motor         | DC 12V                |
| Braking       | Automatic in-the-drum |
| Cable         | 29m / Ø 8.0mm         |
| Recommended   | 650 CCA               |
| Battery       |                       |
| Battery Leads | 1.83m                 |
| Overall Size  | 520x160x218xmm        |

### Line Speed & Amp Draw-First Layer

|               |       |      |
|---------------|-------|------|
| Line Pull     | Kg    | 3626 |
| Line Speed    | m/min | 1.3  |
| Motor Current | amps  | 330  |

### Line Speed & Cable Capacity

|                |    |       |
|----------------|----|-------|
| Layer of Cable |    | 1     |
| Pull Per Layer | Kg | 362.6 |
| Cable Capacity | m  | 5.0   |

Warning: The equipment is intended for Industrial use only and should not be used to lift, support, or otherwise transport people or to suspend loads over people

## LOKPAL INDUSTRIES

A-6, Sector-3, Noida-201301, U.P., India | Tel.: +91-120-3065372 / 75

Website: [www.lokpal.com](http://www.lokpal.com) | E-mail: [info@lokpal.com](mailto:info@lokpal.com)